



Division Waste Management and Radiation Control



**WASTE MANAGEMENT
& RADIATION CONTROL**

USED OIL PROCESSOR PERMIT

Permittee Name: Thermo Fluids Inc.

Permittee Mailing Address: 3545 West 500 South
Salt Lake City, Utah 84104

Permittee Phone Number: Office: (801) 596-4803

Permittee Administrative Contact: Justin Bauer, Sr. Manager Environmental Compliance
Cell: (602) 329-0177
Email: bauer.justin@cleanharbors.com

Facility Address: 3545 West 500 South
Salt Lake City, Utah 84104

Facility Contact: Merv Leituala, Oil Terminal Manager
Office: (801) 596-4803
Cell: (385) 249-8491
Email: leituala.mervyn@cleanharbors.com

Type of Permit: Used Oil Processor Permit

Permit #: UOP-0095

Original Date of Issuance: July 16, 2005

EPA ID #: UTR000008458

Signature: _____ Date: _____

Douglas J. Hansen, Director
Division of Waste Management and Radiation Control

I.A. Effect of Permit

- I.A.1. Thermo Fluids Inc. (hereafter referred to as “Permittee”) is hereby authorized to operate as a Used Oil Processor located at 3545 West 500 South, Salt Lake City, Utah 84104 (Attachment 1 – Facility Site Plan Map) in accordance with all applicable requirements of R315-15 of the Utah Administrative Code and of the Used Oil Management Act (the Act) 19-6-701 et. seq., Utah Code and this Permit.
- I.A.2. This permit shall be effective for a term not to exceed ten years in accordance with the requirements of R315-15-15 of the Utah Administrative Code.
- I.A.3. Attachments incorporated by reference are enforceable conditions of this Permit, as are documents incorporated by reference into the attachments. Language in Conditions I and II supersedes any conflicting language in the attachments or documents incorporated into the attachments.
- I.A.4. It shall not constitute a defense for the Permittee in an enforcement action that it would have been necessary to halt or reduce the Permittee’s business activity in order to maintain compliance with the conditions of this Permit and its attachments.

I.B. Permit Revocation

- I.B.1. Violation of any permit condition or failure to comply with any applicable provision of the applicable statutes and rules shall be grounds for enforcement actions, including revocation of this Permit. The Director shall notify the Permittee in writing of his intent to revoke this Permit.

I.C. Permit Modification

- I.C.1. The Permittee may request modifications to any item or operational activity covered by this Permit by submitting a written permit modification request to the Director. If the Director determines the modification request is substantive, a public hearing, a 15-day public comment period or both may be required before a decision by the Director on the modification request. Implementing a modification prior to the Director’s written approval constitutes a violation of this Permit and may be grounds for enforcement action or permit revocation.
- I.C.2. Changes in operational activities include any expansion of the facility beyond the areas designated, alteration of processing operational parameters, changes in the type or number of storage tanks, piping, other equipment and changes to the contingency plan.
- I.C.3. The Director may require the Permittee to submit additional information when reviewing permit modification requests to ensure the safe handling of used oil at the processing facility in accordance with 19-6-710(3)(b)(xii) of the Utah Code.
- I.C.4. The Director may modify this Permit as necessary to protect human health and the environment or because of statutory or regulatory changes.
- I.C.5. The Permittee shall notify the Director, in writing, of any non-substantive changes, such as changes in the contact person, within 20 days of the change, or because of operation changes affecting this Permit.

I.D. Emergency Controls and Contingency Plan

- I.D.1. The Permittee shall take all reasonable steps to minimize releases to the environment and shall carry out such measures as are necessary to protect human health and the environment. In the event of a release of used oil, the Permittee shall immediately take appropriate actions in accordance with the Permittee's Emergency Controls and Contingency Plan (Attachment 3), and R315-15-9 of the Utah Administrative Code.
- I.D.2. The Permittee shall keep a current copy and all revisions of the Emergency Controls and Contingency Plan (Attachment 3) on site until facility closure.
- I.D.3. The Permittee shall provide a current copy to local police, fire departments, hospitals and State local emergency response teams that may be called upon during an emergency in accordance with R315-15-5.3(b)(3) of the Utah Administrative Code.
- I.D.4. The Permittee shall implement the Contingency Plan when there is an imminent or actual emergency.
- I.D.5. The Permittee shall notify the Utah Department of Environmental Quality 24-hour Answering Service, (801) 536-4123, for used oil releases exceeding 25 gallons or for smaller releases that pose a potential threat to human health or the environment in accordance with R315-15-9.1 of the Utah Administrative Code. The Permittee shall provide the information required by R315-15-9.1(c) of the Utah Administrative Code.
- I.D.6. In accordance with R315-15-9.4 of the Utah Administrative Code, the Permittee shall submit to the Director a written report within 15 days of any reportable release of used oil. The report shall also include a description of actions taken by the Permittee to prevent future spills.

I.E. Facility Equipment, Maintenance and Secondary Containment

- I.E.1 The Permittee shall maintain and operate the facility to minimize the possibility of fire, explosion or sudden or non-sudden release of used oil to air, ground, soil, surface and groundwater and sewer systems that could threaten human health and the environment.
- I.E.2. The Permittee shall have communication systems, fire alert system and fire suppression equipment in place and operational at the facility, as well as arrangements with local emergency response teams (i.e. fire, police and hospital) in accordance with R315-15-5.3 of the Utah Administrative Code.
- I.E.3. The Permittee shall have documentation (hard copy or electronic format) of inspections, conducted weekly, of used oil equipment, secondary containment, containers, tanks, fire suppression systems (portable and fixed), and testing of emergency alarms for fire and emergency communication systems in accordance with Attachment 2 (Safety, Security and Inspection Forms).
- I.E.4. Inspection documents shall include inspector's name, date, areas inspected, any problems found, and the subsequent actions taken by the facility to maintain system integrity.
- I.E.5. To prevent access by unauthorized persons or vehicles during hours when the facility is closed and authorized personnel are not present, the Permittee shall secure the facility, lock the entrance security gate and maintain adequate perimeter fencing.

- I.E.6. The Permittee shall maintain spill kits and fire extinguishers as specified in Attachment 3 (Emergency Controls and Contingency Plan). Locations of the spill kits and fire extinguishers are shown in Attachment 1 (Facility Site Plan Map).
- I.E.7. A secondary containment system for used oil containers, process and storage tanks, and piping and ancillary equipment shall be maintained for the facility in accordance with R315-15-5.5(c) of the Utah Administrative Code. The joints in the concrete pad surrounding the tank farm and any joints in the concrete in the tank farm secondary containment shall be sealed and maintained to prevent migration of oil to the soil and groundwater.
- I.E.8. Used oil, water or other liquids that may accumulate in the secondary containment system or any tertiary containment for ancillary equipment shall be removed within 24 hours of discovery to prevent the possible migration to soil, ground or surface waters.

I.F. Record Keeping Requirements and Retention

- I.F.1. The Permittee shall maintain all used oil records required by R315-15 of the Utah Administrative Code and this Permit at the Permittee's Processor facility located at 3545 West 500 South Salt Lake City, Utah.
- I.F.2. Records may be in hard copy or in an electronic format and shall be readily accessible for inspection by authorized representatives of the Director. The Permittee shall maintain, for a minimum of three years, all applicable used oil processor-tracking records required by R315-15 of the Utah Administrative Code and this Permit.
- I.F.3. The Permittee shall maintain the following records (hard copy or in electronic format) tracking records that document used oil operations conducted at this processing facility.
 - I.F.3.a. Used oil (bulk or containers) accepted at the facility or shipped from the facility in accordance with the requirements of R315-15-5.7(a) and R315-15-5.7(b), respectively, of the Utah Administrative Code.
 - I.F.3.b. Used oil/oily water storage tank records (bulk storage) that document the date, time, operator (signature or initials), source and volume of the used oil deposited into each tank and the date, time, operator (signature or initials), and destination of the used oil removed from each tank (including intertank transfers). In addition, the Permittee shall record the date and time of collection, a sample identification number, and the name of the sampler on tank records for the used oil samples collected from permitted storage tanks.
 - I.F.3.c. Daily inventory of containers of used oil stored at the facility. Containers of used oil filters that have not been properly drained in accordance with R315-15-1.6 of the Utah Administrative Code shall be managed as used oil.
 - I.F.3.d. Records documenting the volume of used oil, water or other liquids (including storm water) removed from the secondary containment system, the date of removal, the operators signature and how the Permittee managed these liquids. Records shall document the operators visually inspection of all storm water for oil contamination prior to transfer to the facility's storm water evaporation pond.

- I.F.3.e. The Permittee shall document the visual inspection of one out of every 20 containers of used oil filters, labeled as properly drained, received at the facility, as required by Condition II.A.12 of this Permit.
- I.F.3.f. The Permittee shall document and maintain records showing the proper characterization, handling, and disposal of used oil related waste streams (Permit Condition I.J.) for a minimum of three years.
- I.F.3.g. Other records (e.g. training and financial assurance) required by R315-15 of the Utah Administration Code and this Permit.

G. Operating Record

- I.G.1. The Permittee shall keep and maintain a written operating record (paper or electronic), available to representatives of the Director, until final closure of the facility that contains the following information:
 - I.G.1.a. All analytical records related to the sampling and analysis of used oil to determine if the used oil meets the specification requirements of R315-15 of the Utah Administrative Code and this Permit, prior to shipment from the facility.
 - I.G.1.b. All records related to the sampling and analysis of used oil related waste streams, as defined in Permit Condition I.J., used to determine if the used oil waste streams are a hazardous waste prior to shipment from the facility.
 - I.G.1.c. All summary reports and details of all incidents that require implementation of the Emergency Controls and Contingency Plan (Attachment 3).
 - I.G.1.d. All records detailing the mass balance of oily wastewater received at the facility, the oily wastewater generated at the facility in tanks via gravity separation, and the oily wastewater generated from tank cleaning activities.

I.H. Sampling and Analysis Plan

- I.H.1. The Permittee shall follow all sampling and analytical procedures in Condition II.D and II.E when conducting used oil sampling and analytical testing to meet the requirements of R315-15-5.6 of the Utah Administrative Code and this Permit.

I.I. Prohibitions

- I.I.1. The Permittee shall not manage used oil in surface impoundments or waste piles.
- I.I.2. The Permittee shall not place, manage, discard or otherwise dispose of used oil in any manner specified in R315-15-1.3 of the Utah Administrative Code.
- I.I.3. Used oil that has been mixed with hazardous waste as defined by R315-261 of the Utah Administrative Code, or PCBs as defined by R315-301-2(53) of the Utah Administrative Code shall no longer be managed as used oil and shall be subject to the rules applicable to hazardous waste and PCB-contaminated waste.
- I.I.4. Used oil shall not be stored in containers; tanks or piping that have previously stored hazardous waste, unless the tanks, containers and piping are cleaned in accordance with R315-261-7 of the Utah Administrative Code.

- I.I.5. The Permittee shall not accept used oil for storage with a PCB concentration greater than or equal to 2 mg/kg (ppm). Used Oil shall not be diluted to avoid any provision of any Federal or State environmental regulations.
- I.I.6. Used oil shall not be stored in tanks, containers, associated piping, or storage areas contaminated with PCBs at or above 2 mg/kg (ppm). Any tanks, containers, piping or storage areas that have been contaminated with PCBs shall be immediately decontaminated in accordance with 40 CFR 761 Subpart S.
- I.I.7. Any used oil that was mixed with the PCB-contaminated material at or greater than 2 mg/kg shall be managed in accordance with R315-15-18 of the Utah Administrative Code and 40 CFR 761 Subpart S.

I.J. Waste Characterization and Disposal

- I.J.1. All wastes generated during used oil operations shall be handled in accordance with this Permit and R315-15 of the Utah Administrative Code. The wastes shall be transported to an appropriate facility permitted to handle the type of waste generated.
- I.J.2. The Permittee shall sample and analyze used oil related waste streams, generated at the facility, to determine if the wastes are hazardous or non-hazardous in accordance with R315-261 and R315-15-8 of the Utah Administrative Code prior to shipment from the facility.
- I.J.3. Oily wastewater (rinsate) and other wastes materials generated from the cleaning of permitted tanks, piping, auxiliary equipment, used oil storage areas, and secondary containment areas shall be sampled and analyzed to determine if they are hazardous or non-hazardous wastes prior to shipment from the facility.
- I.J.4. The Permittee shall sample and analyze all “process wastewater”, prior to shipment from the facility, to determine if it is a hazardous or a non-hazardous waste to assure proper management of this waste stream. The definition and description of “process wastewater” is defined below.
 - I.J.4.a. The Permittee processes used oil/oily water received at the facility, via gravity separation, in the facility’s designated used oil/oily water tanks (Table II.E). Processing of the used oil/oily water, via gravity separation, generates a recoverable oil phase and an oily water phase. The oily water phase contains “emulsified oil” that is not recoverable by the Permittee’s oil processing techniques. The oily water phase is defined herein as “process wastewater” only if the Permittee ships this oily water to a facility that does not recover and recycle the used oil from the oily water (e.g., wastewater treatment facilities and landfills).
 - I.J.4.b. The definition of “process wastewater” does not apply to the oily water phase when shipped from the facility to a used oil processing facility, regulated under R315-15-5 of the Utah Administrative Code, that further processes, recovers and recycles the used oil remaining in the oily water. The oily water is still regulated as used oil.
- I.J.5. The Permittee shall notify the Director within 24 hours of any used oil found at the facility with PCB concentrations greater than or equal to 2 mg/kg (ppm).

I.K. Liability and Financial Assurance Requirements

- I.K.1. The Permittee shall be financially responsible for cleanup and closure costs, general liabilities and environmental pollution legal liability for bodily or property damage to third parties resulting from sudden release of use oil in accordance with R315-15-10 through 12 of the Utah Administrative Code and this Permit.
- I.K.2. The Permittee shall provide documentation of financial responsibility, for cleanup and closure, environmental pollution legal liability, and general liability coverage annually to the Director for review and approval by March 1 of each reporting year or upon request by the Director.
- I.K.3. The Permittee shall receive written approval from the Director for any changes in the extent, type (e.g., mechanism, insurance carrier or financial institution), or amount of the environmental pollution legal liability or financial assurance mechanism for coverage of physical or operational conditions at the facility that change the nature and extent of cleanup or closure costs prior to implementation of these changes.

I.L. Cleanup and Closure Plan

- I.L.1. The Permittee shall update the facility closure plan cost estimates and provide the updated estimate to the Director, in writing, within 60 days following a facility modification that causes an increase in the financial responsibility required under R315-15-10 of the Utah Administrative Code. Within 30 days of the Director's written approval of a permit modification for the cleanup and closure plan that would result in an increase cost estimate, the Permittee shall provide to the Director the information specified in R315-15-11.2(b)(2) of the Utah Administrative Code and Condition II.G of this Permit.
 - I.L.1.a. The Permittee shall submit to the Director at the time of the closure of the facility, an updated closure plan. The Permittee shall receive written approval from the Director prior to implementing the updated closure plan.
- I.L.2. The Permittee shall initiate closure of the facility within 90 days after the Permittee receives the final volume of used oil or after the Director revokes the Permittee's Processor Permit in accordance with the requirements of R315-15-11.3 of the Utah Administrative Code and this Permit.
- I.L.3. The Permittee shall remove or decontaminate used oil residues in tanks, containment system, and the environment in accordance R315-15-5.5(f) of the Utah Administrative Code and this Permit's Closure Plan (Attachment 8).
- I.L.4. Within 60 days of completion of cleanup and closure, the Permittee shall submit to the Director, by registered mail, a certification that the facility has been closed in accordance with R315-15-11.4 of the Utah Administrative Code and the specifications of the approved cleanup and closure plan. An independent, Utah-registered professional engineer and the Permittee shall sign the closure certification.

I.L.5. The Director may require that the Permittee perform additional sampling or remediation actions to verify that cleanup and closure has been completed according to R315-15 of the Utah Administrative Code.

I.M. Used Oil Handler Certificate

I.M.1. In accordance with R315-15-5.9 of the Utah Administrative Code, the Permittee shall not operate as a used oil processor without obtaining annually a Used Oil Handler Certificate from the Director. The Permittee shall pay a used oil handler fee, pursuant to Utah Administrative Code Section 63J-1-504, by December 31 of each calendar year to receive certification for the upcoming calendar year.

I.N. Inspection and Inspection Access

I.N.1. Any duly authorized representative of the Director may, at any reasonable time and upon presentation of credentials, have access to and the right to copy any records relating to used oil and to inspect, audit or sample. The representative may also make record of the inspection by photographic, electronic, audio, video or any other reasonable means to determine compliance.

I.N.2. The authorized representatives may collect soil, groundwater or surface water samples to evaluate the Permittee's compliance.

I.N.3. Failure to allow reasonable access to the property by authorized representatives is a "denial of access" and may be grounds for enforcement action or permit revocation.

I.O. Annual Report

I.O.1. As required by R315-15-13.5 of the Utah Administrative Code, the Permittee shall prepare and submit an Annual Report to the Director by March 1 of the following year. The Annual Report shall describe the Permittee's used oil activities in Utah and document financial assurance using the Division's Processor Annual Report form.

I.P. Other Laws

I.P.1. Nothing in this permit shall be construed to relieve the Permittee of his obligation to comply with any Federal, State or local law.

I.Q. Enforceability

I.Q.1. Violations documented through the enforcement process pursuant to Utah Code 19-6-112 may result in penalties assessed in accordance with R315-102 of the Utah Administrative Code.

I.R. Effective Date

I.R.1. The permit is effective on the date of signature by the Director.

II.A. General Operations

- II.A.1. The Permittee is authorized to accept from Utah permitted Used Oil transporters, store and process used oil via simple filtration, gravity separation used oil in accordance with R315-15-5 of the Utah Administrative Code at 3534 West 500 South, Salt Lake City, Utah. The Permittee also operates as a large quantity handler of Universal Waste (Antifreeze) at this facility.
- II.A.2. The Permittee is authorized to store a maximum of 777,822 gallons of used oil in tanks, associated piping, containers and 120 cubic yards of undrained used oil filters in steel bins or drums.
- II.A.3. The Permittee shall have a current process and instrument diagram (PID), certified by a Utah professional engineer (Attachment 4 – PID Diagram). Any modification to the facility, including the PID drawing, requires Director’s approval.
- II.A.4. The Permittee shall only store used oil in tanks, containers or units subject to regulations under R315-265 or R315-264 of the Utah Administrative Code and maintain tanks, containers, associated piping, pumps and valves in good operational condition.
- II.A.5. The Permittee may only accept used oil from a Utah-permitted used oil transporter or deliveries of exempted oily wastewater from waste haulers that maintain all required permits or registrations with the State, counties or municipalities.
- II.A.6. The Permittee shall verify, at the time of acceptance, that the transporter delivering the used oil has recorded the halogen content of the used oil on the shipping documents.
- II.A.7. The Permittee is not required to further test used oil from a Utah-registered used oil marketer if the marketer provides, at the time of acceptance, analytical data results documenting that the used oil has been tested for the parameters in R315-15-1.2 of the Utah Administrative Code.
- II.A.8. If the transporter has not documented the halogen content on the shipping records, then the Permittee shall determine the halogen content of the shipment of used oil, prior to acceptance at the facility.
 - II.A.8.a. The Permittee shall determine the halogen content by collecting a representative sample in accordance with Condition II.E. and Attachment 5 (Sample Collection Procedures), and by screening the used oil sample for halogens, or by submitting the sample to a Utah-certified laboratory for analysis in accordance with the analytical requirements of Attachment 6 (Analysis Plan).
 - II.A.8.b. The Permittee shall then record the results of the halogen testing in the facility operating record.
- II.A.9. The Permittee shall utilize a Utah Used Oil Permitted Transporters to deliver shipments of used oil in accordance with R315-15 of the Utah Administrative Code.
- II.A.10. Used oil recovered from oily water shall be managed as used oil in accordance with R315-15 of the Utah Administrative Code and this Permit.

II.A.11. The Permittee shall visually inspect one out of every 20 containers of used oil filters (labeled as properly drained) received at the facility to verify the used oil filters are properly drained in accordance with R315-15-1.6 and R315-261-4(b)(13) of the Utah Administrative Code.

II.B. PCB Contaminated Used Oil

II.B.1. The Permittee shall notify the Director within 24 hours of any used oil with a PCB concentration greater than or equal to 2 mg/kg (ppm). Used oils containing PCB concentrations greater than or equal to 2 mg/kg but less than 50 mg/kg are subject to both R315-15 of the Utah Administrative Code and 40 CFR 761.

II.C. Used Oil Loading and Unloading Requirements

II.C.1. The Permittee shall ensure that operations involving the loading or unloading of used oil are conducted in accordance with Attachment 7 (Used oil Loading and Unloading Procedures).

II.D. Used Oil Sampling and Analysis

II.D.1. The Permittee shall ensure a representative sample is collected from tanks, totes, drums or other containers in accordance with Attachment 5 (Used Oil Sample Collection Procedures). Sampling personnel shall be trained on appropriate sampling methods for each type of container and matrix.

II.D.2. Samples collected from bulk oil/oily water containers greater than 550 gallons shall be individual samples, not composite samples.

II.D.3. A representative composite sample may be collected from individual drums or containers containing used oil from the same source. A representative composite sample may consist of not more than four drums/containers or 550 gallons, whichever is less, per composite sample. The individual samples shall be taken and consolidated into one representative composite sample (Attachment 5 – Sample Collection Procedures) and tested.

II.D.4. Drums or containers of used oil from different sources or processes shall be sampled individually.

II.D.5. A COLIWASA shall be used to collect samples from drums or containers less than or equal to 275 gallons. The entire COLIWASA contents shall be placed in the sample container.

II.D.6. The Permittee shall analyze used oil and other related materials in accordance with the requirements of Attachment 6 (Analysis Plan).

II.E. Used Oil Storage

II.E.1. The Permittee shall only store bulk used oil, containers of used oil and oily water, in used oil storage tanks and container storage areas that are identified and described in Table II.E.

Table II.E: Description of the facility storage tanks and container storage areas.

Tank No.	Capacity (Gallon)	Container Type	Type of Storage and Location
DT-1	27,073	Steel Tank	Flexible Storage Tank - Used Oil or Oily Water/Secondary Containment Tank Farm
DT-5	12,263	Steel Tank	Universal Waste Antifreeze Secondary Containment Tank Farm
DT-6	12,263	Steel Tank	Universal Waste Antifreeze/Secondary Containment Tank Farm
DT-7	12,263	Steel Tank	Universal Waste Antifreeze/Secondary Containment Tank Farm
DT-8	16,144	Steel Tank	Universal Waste Antifreeze/Secondary Containment Tank Farm
DT-17	19,905	Steel Tank	Used Oil/Secondary Containment Tank Farm
DT-18	19,905	Steel Tank	Used Oil/Secondary Containment Tank Farm
DT-19	19,905	Steel Tank	Used Oil/Secondary Containment Tank Farm
DT-20	19,905	Steel Tank	Used Oil/Secondary Containment Tank Farm
DT-21	19,905	Steel Tank	Used Oil/Secondary Containment Tank Farm
DT-22	19,905	Steel Tank	Used Oil/Secondary Containment Tank Farm
DT-23	21,020	Steel Tank	Used Oil/Secondary Containment Tank Farm
DT-24	20,558	Steel Tank	Used Oil/Secondary Containment Tank Farm
TK-25	259,095	Steel Tank	Flexible Storage Tank Used Oil or Oily Water/Secondary Containment Tank Farm
TK-26	259,095	Steel Tank	Used Oil/Secondary Containment Tank Farm
OW-2	14,763	Steel Tank	Oily Water/Secondary Containment Tank Farm
OW-3	20,344	Steel Tank	Oily Water/Secondary Containment Tank Farm
OW-4	20,344	Steel Tank	Oily Water/Secondary Containment Tank Farm
Filter Pots	900	Steel Filter Pot	Used Oil/Secondary Containment Tank farm
Drums (55 gal)	8,250	Steel/Poly Drums	Used Oil Container Storage Area Concrete Pad (150 drums maximum)
Drums (55 gal)	NA	Steel/Poly Drums	Non-Hazardous Wastes (e.g. grease, properly drained used oil filters). Storage area not defined
Totes (330 gal.)	6,600	Steel/Poly Totes	Used Oil Container Storage Area Concrete Pad (20 totes maximum)
Roll Off Bins/Drum	120 cubic yards	Roll Off Bins / Drums	Oil Filters Bin Storage Area Concrete Pad
Auxiliary Equipment	350	Piping	Tank farm piping and other auxiliary equipment
Maximum facility used oil storage capacity = 777,822 gallons			

- II.E.2. The Permittee shall conduct inspections of used oil storage containers, tanks and secondary containment systems in accordance with Attachment 2 (Safety, Security and Inspection Forms) of this Permit. The Permittee shall record the inspector's name, the time and date of the inspection and the condition of the tanks, storage containers and secondary containment systems. The Permittee shall document in the inspection log any issues discovered during the inspections (e.g. leaking tanks or water accumulation) and any actions taken by the Permittee to resolve these issues.
- II.E.3. The Permittee shall label used oil storage tanks, piping, drums and containers with the words "Used Oil". Drums or containers with any undrained used oil filters shall be labeled as "Used Oil or Used Oil Filters (Undrained)."
- II.E.4. The Permittee shall keep drums and containers of used oil closed except while removing or adding used oil.
- II.E.5. The Permittee may not store used oil in units other than tanks, containers, or units subject to regulations under R315-264 or R315-265 of the Utah Administrative Code.
- II.E.6. The Permittee may store used oil or oily water in flexible storage tanks DT-1 and TK-25.
- II.E.6.a. Tank DT-1 and TK-25 shall be properly labeled to identify the type of material being stored. DT-1 and TK-25 tank records will document any changes in the type of material being stored in this tank and the date of the change.

II.F. Specific Operations

- II.F.1. The Permittee shall verify, by visually inspection or sample analysis that the storm water accumulated in the secondary containment area has not been contaminated with used oil prior to the transfer into the facility's storm water evaporation pond.
- II.F.1.a. The Permittee shall document in the operating record the date, time, operator signature, and volume of oil-free storm water pumped from the secondary containment area into the facility's storm water evaporation pond. The record shall specify how the operator determined the stormwater was oil-free in accordance with II.F.1.
- II.F.2. The Permittee shall only transfer accumulations of oily stormwater (PCBs < 2 ppm), into facility tanks designated for oily water storage (Table II.E.).
- II.F.3. Incoming bulk used oil with a PCB < 2 ppm, may be transferred into tanks DT-17, DT-18, DT-19, DT-20, DT-21, DT-22, DT-23, DT-24, TK-26, and tanks DT-1, and TK-25 when these storage tanks are designated for used oil storage.
- II.F.4. Containers (drums and totes) of used oil (<2 mg/kg PCB) and undrained used oil filters shall be stored in the Used Oil Container Storage Area (Attachment 1).
- II.F.4.a. The used oil in containers may be transferred into the bulk storage tanks or shipped off site for recycling.
- II.F.5. The Permittee shall document that the used oil meets the specification requirements of R315-15-1.2 of the Utah Administrative Code prior to shipment from the facility to a used oil burner.

II.G. Used Oil Training

- II.G.1. The Permittee shall train handlers of used oil in accordance with R315-15 of the Utah Administrative Code and the requirements of this Permit. New employees may not conduct used oil operations, including oil transfers, recordkeeping, and sampling without a trained employee present until the new employee's used oil training is completed and documented.
- II.G.2. Employee training shall include documentation that the following topics were covered: identification of used oil, recordkeeping requirements and facility used oil procedures for handling, transporting, sampling and analysis, emergency response, spill reporting and personal safety.
- II.G.3. The Permittee shall provide, at a minimum, an annual used oil-training refresher course for employees handling used oil. Additional training is required for employees if the Permittee updates or changes used oil-handling procedures at the facility
- II.G.4. The Permittee shall keep training records for each employee for a minimum of three years. Employees and supervisors shall sign and date training attendance sheets to document class attendance.
- II.G.5. Employees shall demonstrate competence to collect a representative used oil sample and analyze the oil for halogens using a CLOR-D-TECT® or HydroClor® at the facility prior screening used oil or oily-water in the field.

II.H. Facility Closure

- II.H.1. The Permittee shall submit a modified closure plan in Attachment 8 (Facility Closure Plan) to the Director for approval, prior to closure implementation. The modified closure plan shall evaluate the potential impacts of used oil operations on the surrounding soil, groundwater and surface water in accordance with R315-15-11 of the Utah Administrative Code. The Permittee shall be responsible for any cleanup of any used oil contamination that has migrated beyond the facility property boundaries in accordance with R315-15-11(d) of the Utah Administrative Code and this Permit.

II.I. Emergency Spill Response and Remediation

- II.I.1. In accordance, with R315-15-9.1 of the Utah Administrative Code, the person responsible for the spill shall immediately take appropriate action to minimize the threat to human health and the environment and notify the DEQ Hotline at (801) 536-4123 if the spill is greater than 25 gallons or smaller spills if it poses a threat to human health or the environment (Attachment 3 – Emergency Controls and Contingency Plan).
- II.I.2. Responders shall take action to prevent spills from spreading by utilizing absorbent, dirt, booms, pads, rags, etc.
- II.I.3. The Permittee is responsible for the material release and shall recover oil and remediate any residue from the impacted soils, water, or other property, or take any other actions as required by the Director until there is no longer a hazard to human health or the environment.

- II.I.4. Once the material is containerized, a waste determination shall be made to determine the material's disposition.
- II.I.5. The Director may require additional cleanup action to protect human health or the environment.
- II.I.6. All costs associated with the cleanup shall be at the expense of the Permittee.
- II.I.7. Spill kits shall contain, at a minimum, the equipment listed in Attachment 3 (Emergency Controls and Contingency Plan).
- II.I.8. The Permittee shall document in the operating record all relevant information, including the amount of waste generated from cleanup efforts, the characterization of the waste (i.e. hazardous or non-hazardous), final waste determination, and disposal records. The report shall also include actions taken by the Permittee to prevent future spills.
- II.I.9. In accordance with R315-15-9.4 of the Utah Administrative Code, the Permittee shall submit to the Director a written report within 15 days of any reportable release of used oil.

Attachment 1: Facility Site Plan Map

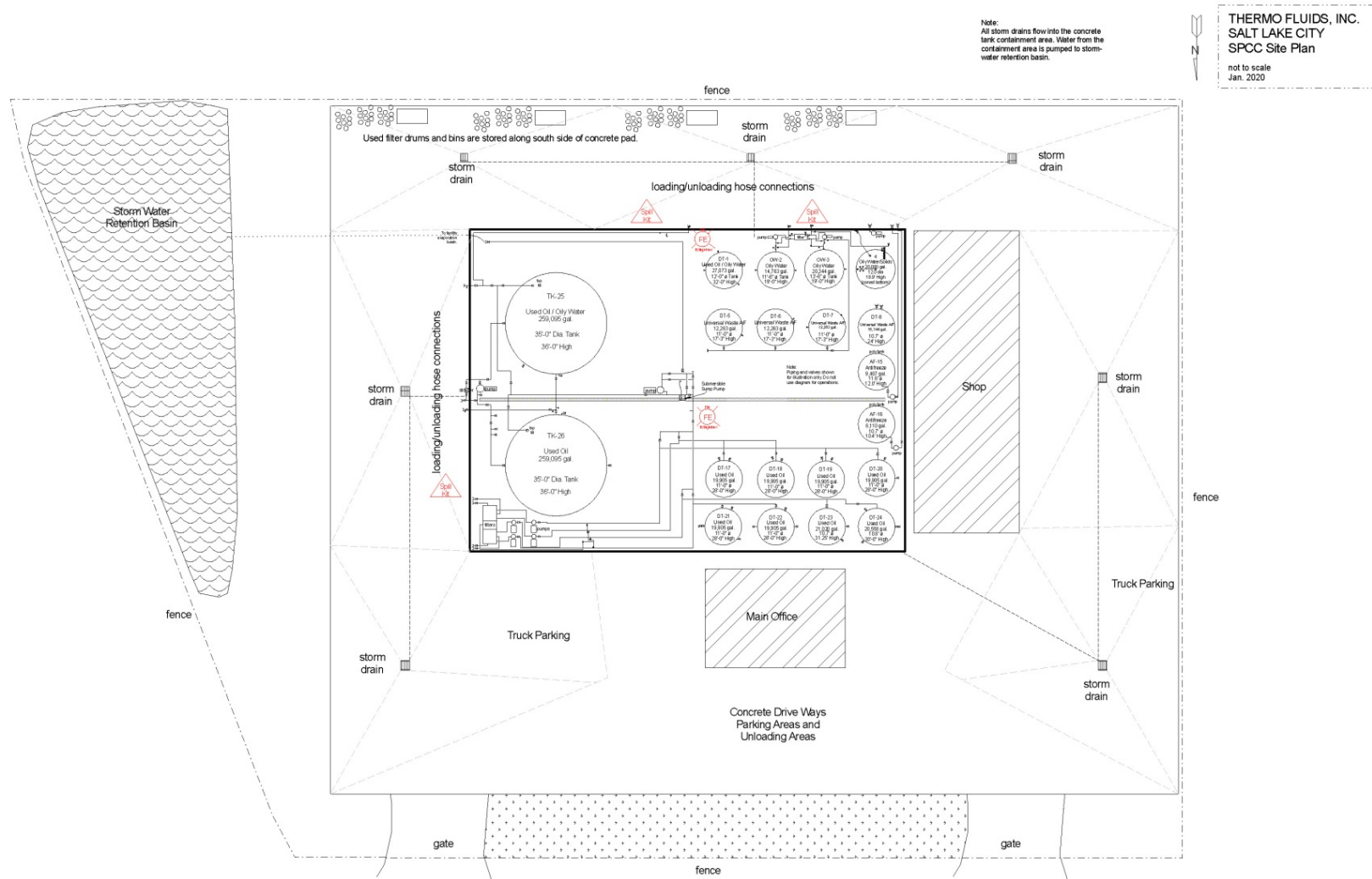

Attachment 2

Safety, Security and Inspection Forms

A. Purpose

- A.1. This procedure is designed to meet the used oil regulatory requirements for the maintenance and inspection of R315-15 of the Utah Administrative Code and Thermo Fluids Inc.'s (Thermo) Used Oil Processor Permit to assure the protection of human health and the environment. The location of the used oil storage areas and emergency equipment are shown in Attachment 1.

Thermo shall document the inspection and maintenance of used oil containers, tanks, fire suppression systems (portable and fixed), and facility emergency equipment and alarms. Thermo's Branch Manager is responsible for the implementation of the inspection program. Comprehensive inspection forms shall be used for inspection and Safety/Emergency Equipment (Appendix 1 & 2); not all items on forms are applicable to this facility).

Inspection forms consist of either a written hardcopy or equivalent record in an electronic format. Inspection forms and any associated documents (i.e. actions taken due to deficiencies) shall be incorporated into the Facility's Operating Record.

B. Inspections

- B.1. Used oil storage areas shall be inspected, at a minimum, according to the frequency specified in Table 1 and Attachment 2, Appendix 1 & 2.
- B.1.a. Inspectors are required to document the date and time of inspection, name of the inspector, the status of each inspected item. The inspector shall mark any items that are on the "generic" inspection list that are not specifically applicable to the Permittee's facility, as "NA" on the inspection forms
- B.1.b. The Permittee shall document that all deficient conditions found during the weekly inspections were reported to Thermo's facility manager. Thermo's facility manager will verify (written or electronic documentation) that any deficiencies identified during the inspection were corrected in a timely manner and that used oil spills were immediately cleaned-up.
- B.1.c. The inspector is required to check each item on the form and indicate whether its condition is acceptable or unacceptable.
- B.1.c.1. If the status of a particular inspection item (e.g., tanks, valves, piping or other auxiliary equipment) identified in the facility's PID drawing in Attachment 4 is not functioning as designed (completely or partially), the inspector will describe in detail the deficiency in the comment section of the inspection report.
- B.1.c.2. In addition, at the time of inspection the inspectors will document in the comment section any deficiencies found for equipment signage, safety equipment or emergency spill supplies that are required by the Permit.

- B.1.c.3. If the inspector takes corrective actions for a deficient condition at the time of inspection, then the inspector shall record what actions were taken in the comment section. The comment section shall include the date that the unacceptable/deficient condition was reported to facility management.
- B.2. Inspectors shall receive training to enable them to identify any problems associated with the used oil storage areas or emergency equipment. These records shall be maintained at the facility in a readily available location and maintained for a minimum of three years from the applicable record's inspection date

Table 1: Frequency of Used Oil Inspections

Inspection Type	Items Inspected	Frequency
Use Oil Storage Areas	<ul style="list-style-type: none"> • Tanks/Auxiliary piping/Valves • Containers and container storage areas • Secondary Containment Areas 	Weekly
Emergency Equipment	<ul style="list-style-type: none"> • Spill Kits/Eye wash • Fire extinguishers • Alarm Horns and Communication System • Personal Safety Equipment • First Aid Kits 	Weekly

Attachment 2 - Appendix 1
Weekly SPCC Inspection

Compliance Header	
Inspector Name	
Area of Inspection	
Inspection Date and Time	
Weekly SPCC Inspection Instructions	
Fully explain all items that need immediate attention in the comment section after each question that fails. Include the location of the deficiency and the corrective action necessary.	
A. Drainage/Containment	
Any noticeable sheen on run off?	
Containment area drainage valves closed and locked?	
No visible oil sheen in containment area?	
No standing water in containment area or sump?	
Containment floor and walls free of cracks?	
Containment free of weeds (inside and out)?	
Drip pans not overflowing, properly labeled	
B. Pipelines	
No sign of corrosion or other damage to pipes and or supports?	
Buried pipes are not exposed (if applicable)?	
Out of Service Pipes capped?	
Signs and barriers to protect pipelines from vehicles are in place and visible?	
No leaks at valves, flanges or other fittings (check EACH connection)?	
C. ASTs	
Tank surfaces checked for signs of leakage?	

Tank condition good (no rusting, corrosion, pitting)?	
Bolts, rivets, and or seams are not damaged?	
Tank foundation intact?	
Level gauges and alarms working properly?	
Vents not obstructed?	
Manways, flanges, and gaskets free from leaks?	
D. Truck Loading/Unloading Area	
No standing water in rack area?	
No leaks in hoses, stored with caps in place?	
Drip pans not overflowing, properly labeled?	
Catch basins free of contamination?	
Containment curbing or trenches intact?	
Connects are capped or blank flanged?	
Eye wash station available and functioning and stocked?	
E. Security	
Fence and gates intact?	
Access doors and overhead doors have locks?	
AST valves locked when not in use?	
Starter controls for pumps locked when not in use?	
Lighting is sufficient and functioning properly?	
Compliance Footer	
Inspector Signature	
Attach Photo	
Inspection Overall Assessment	

Attachment 2 – Appendix 2
Safety and Security Inspection

Compliance Header	
Inspector Name	
Area of Inspection	
Inspection Date and Time	
CO Safety Security Inspection Instructions	
Note condition of inspection items. If item does not apply to an area, mark N/A. All unsatisfactory findings must be explained below. Include any repairs, changes or other remedial actions required or performed.	
CO Safety Security Inspection Items	
Perimeter Fences - Check for evidence of failure (e.g., broken ties, corrosion, holes, distortion, other).	
Gates/External Warehouse Doors - Check for evidence of failure (e.g., locking mechanism, broken ties, corrosion, holes, distortion, direct access doors working properly, other).	
Warning Signs - Check for evidence of failure (e.g., missing, faded, other).	
Exit Signs - Check for evidence of failure (e.g., missing sign, illumination, lamp bulbs, battery backup, other).	
Exits/Firelanes/Evacuation Routes - Check that all routes are clear or unobstructed.	
Lighting System - Check for evidence of failure (e.g. expired lamps, effectiveness, location, other).	
Emergency Lighting System - Check for evidence of failure (e.g., expired lamps, battery backup, effectiveness, other).	
Accessibility of Safety Equipment/Protective Gear - Check for evidence of availability (e.g., hardhats, face shields, goggles, safety glasses, boots, gloves, aprons, uniforms, duct tape, absorbents, other).	
Adequate Supply of Safety Equipment/Protective Gear - Check for evidence of availability (e.g., cleanliness, inventory available, other).	
Condition of Safety Equipment - Check for evidence of failure (e.g.,	

review PPE for damage or excessive wear, other).	
Breathing Apparatus Accessibility - Check for evidence of availability (e.g. SCBA respirators, equipment, other).	
Breathing Apparatus Adequate Supply/Full Charge - Check for evidence of availability (e.g., SCBA tanks, charged, other).	
Breathing Apparatus Condition - Check for evidence of failure (e.g., SCBA damage, other).	
First Aid Kits - Check for evidence of availability (e.g., adequate inventory, other).	
Bloodborne Pathogen Kits - Check for evidence of availability (e.g., adequate inventory, other).	
Emergency Eyewashes - Check for evidence of failure (e.g., disconnected or malfunctioning valves, inadequate pressure, inaccessible, malfunctioning drain, leaking, other).	
Emergency Showers - Check for evidence of failure (e.g., disconnected or malfunctioning valves, inadequate pressure, inaccessible, leaking, other).	
Internal/External Communication - Check for evidence of failure (e.g., inadequate supply of phones or radios, malfunctioning intercom, telephones not working properly, emergency alarm does not work, phone moved from proper location, other).	
Fire Extinguishers - Check for evidence of failure (e.g., overdue inspection, not charged, inaccessible, other).	
Absorbent Supply - Check for evidence of availability (e.g., adequate inventory, other).	
Recovery Drum Supply - Check for evidence of availability (e.g., adequate inventory, other).	
Respirators and Cartridges - Check for evidence of availability (e.g., adequate APR inventory, other).	
Fire Suppression System Accessibility - Check for evidence of failure (e.g., monitors, pull stations, alarms, other).	
Fire Suppression System Operable - Check for evidence of failure (e.g., test, other).	
Water Lines/Hydrants - Check for evidence of failure (e.g., blocked, broken, other).	

Alarm Systems - Check for evidence of failure (e.g., test, other).	
Fire Blankets - Check for evidence of availability (e.g., adequate inventory, other).	
Strainer on Fire Suppression System - Check for evidence of failure (e.g., functioning as intended, other).	
Surveillance System/Guard Service - Check for evidence of failure (e.g., equipment or service provided and functioning properly, other).	
Supplied Air Delivery System and Reserve - Check for evidence of failure (e.g., system operational, equipment functioning, other).	
Decontamination Equipment/Spill Clean-up Equipment - Check for evidence of availability (e.g., adequate supply of shovels, mops, cleaning solvents, available inventory, other).	
Portable Sump Pumps - Check for evidence of availability (e.g., adequate inventory, functioning properly, other).	
Gasoline Pumps - Check for evidence of failure (e.g., broken parts, leaks, other).	
Loud Speakers - Check for evidence of failure (e.g., test, other).	
Chocked Wheels on Parked Vehicles - Check for evidence of failure (e.g., chocks not used, missing, deteriorated, other).	
Cylinders Secure - Check for evidence of failure (e.g., properly stored, secured, chained, other).	
Ventilation Operable - Check for evidence of failure (e.g., system working as intended, other).	
Fall Protection - Check for evidence of availability (e.g., adequate inventory, integrity of equipment, other).	
Electrical Boxes - Check for evidence of failure (e.g., closed, not blocked, marked properly, other).	
Emergency Contact Info Posted - Check for evidence of availability (e.g., up-to-date postings, location requirement, other).	
Hearing Protection Available - Check for evidence of availability (e.g., type appropriate per location, other).	
Housekeeping - Check for evidence of failure (e.g., blocked egress, proper storage, procedure followed, other).	

Portable Compressor - Check for evidence of availability (e.g., adequate inventory, functioning properly, other).	
Lime Supply - Check for evidence of availability (e.g., adequate inventory, other).	
QC Lab Hood - Check for evidence of failure (e.g., functioning properly, other).	
Roll off Parking Area - Check for evidence of failure (e.g., housekeeping, staging, other).	
Dumpster/Outside Containers - Check for evidence of failure (e.g., housekeeping, condition, appropriate use and storage, other)	
Storm water Collection System - Check for evidence of failure (e.g., functioning properly, damaged equipment, integrity, other).	
Rally Point - Check for evidence of failure (e.g., location identified, communication, other).	
Visitor Log - Check for evidence of failure (e.g., available, communication, proper use, other).	
Contingency Plan - Check for evidence of failure (e.g., available, up-to-date, communication, other).	
Wind Instrument/Wind Sock - Check for evidence of failure (e.g., operational, functioning properly, not broken, other).	
Compliance Footer	
Inspector Signature	
Attach Photo	
Inspection Overall Assessment	

Attachment 3

Emergency Controls and Contingency Plan

A. Introduction

A.1. This Emergency Control and Contingency Plan is designed in accordance with the requirements of the Utah Administrative Code R315-15.5 to implement a contingency plan and emergency procedures including the appropriate equipment required to minimize hazards to human health or the environment from fires, explosions, or any unplanned sudden or non-sudden release of used oil to air, soil, or surface water. This plan also establishes activities required of Thermo Fluid Inc.'s personnel to carry out to mitigate such discharges (i.e., countermeasures) should they occur. The Emergency Control and Contingency Plan is to be used in association with the facility's Spill Prevention Control and Countermeasures Plan (SPCC) (SPCC Plan is not incorporated into this Permit).

B. Facility Description and Operations

B.1. The facility stores used oil on-site for periods exceeding 35 days. The used oil is stored in drums, totes or tanks. Sufficient secondary containment is provided in all storage areas per requirements of R315-15-5 of the Utah Administrative Code and the Spill Prevention Control and Countermeasures regulations.

C. Site Security

C.1. The facility operates during normal business hours. A chain-link fence surrounds the area that includes all of the facility's structures. At night, the facility's operational areas are lighted. Access to the facility is restricted to employees, contractors, vendors and authorized visitors. Storage tanks and containers are located inside the facility's secured area.

D. Commitment of Manpower and Resources

D.1. The facility shall have an emergency coordinator at the facility or on call that is available to respond to a facility emergency immediately. The primary and secondary emergency coordinators are listed in Table D.1, below. The emergency coordinators shall be thoroughly familiar with all aspects of the facility's emergency control and contingency plan, facility operations, and have the authority to commit the resources needed to carry out the contingency plan. In their absence, all facility and office personnel will evacuate, and the most senior employee will contact the emergency coordinators.

Table D.1: Facility Emergency Coordinators and Contact Information

Emergency Coordinators	Title	Contact Information
Merv Leituala	Oil Terminal Manager	Office Phone: 801-596-4803 Cell Phone: 385-249-8491
Joe Valerio	Area Terminal Director	Cell Phone: 509-998-6671

E. Facility Emergency Equipment

E.1. The facility is equipped with the emergency equipment listed in Table E.1. All emergency equipment is inspected and maintained as necessary to assure its proper operation in time of emergency.

Table E.1: List of Facility Emergency Equipment

Physical Description	Location	Capabilities/Intended Use
Spill Control Equipment	Loading Pad	Secondary spill containment
Absorbent materials	Loading Pad	Spill clean-up
Fire extinguishers	Perimeter of tank farm	Extinguish fires, dry chemical type
First aid kit	Inside Office	Treat minor injuries
Tools	Inside Warehouse	Various repairs
Recovery drum	Loading Pad	Secondary Containment
Eye wash stations	Inside Warehouse	Employee safety from chemical splashes
Safety and warning signs	Loading Pad	Employee safety
Hard hats, safety glasses, goggles, and face shields	On Trucks / Spares in Office	Protection handling
Chemically resistant gloves, boots, rain suit, apron	Gloves on Trucks / Boots and Rain Suits in Office	Protection
Communications system	Air horns on loading pad / Driver cell phones	Emergency Calls
Decontamination Equipment	Vacuum truck on property	Clean Spills

E.2. Spill kits shall contain, at a minimum, the equipment listed in Table E.2.

Table E.2: Spill Kit Equipment Requirements

Equipment Description	Quantity
Scoops inside Spill Kits and large shovels/Brooms available in the vicinity of the Spill Kits	1
Buckets	1
Spill Pad	10
Granulated Absorbent	2 ft ³
Boom/Oil Socks	1
Spill Plan with Emergency Contact Numbers (Available in Office)	1
Blank Spill Report Sheets (Available in Office)	2

F. Communication

- F.1. In the event of an emergency or used oil spill, employees will use cell phones and in-person verbal communication to notify employees of the emergency and any need to evacuate and also to contact the supervisors and emergency coordinators and provide details regarding the emergency or spill event.

G. Facility Emergency Evacuation Plan

- G.1. In the event of a serious spill, fire, or explosion, which presents possible hazards to human health and to the environment, all personnel will immediately evacuate the premises in accordance with the following procedures.
- G.2. Cell phones will be used to alert employees of an emergency.
- G.3. Employees shall muster at the parking lot directly across the street at the corner of 2400 South and 800 West for further instructions (Figure G.3- Emergency Evacuation Route Diagram).

Figure G.3: Facility Evacuation Routes

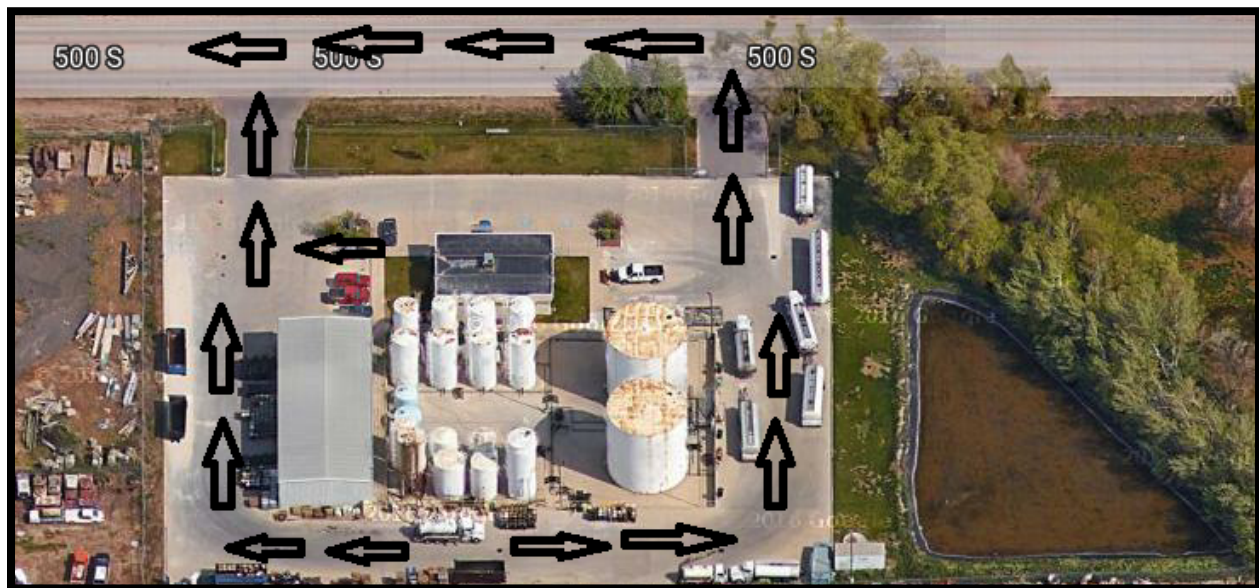

H. Coordination Agreements

- H.1. A copy of the Emergency Control and Contingency Plan and all revisions will be sent to the government agencies and prime emergency responders. A copy of the plan will be maintained onsite.
- H.2. The fire department is familiar with the facility layout, products transferred, stored, and handled, and hazardous waste stored.

I. Spill Control, Emergency Response and Reporting Requirements

- I.1. Thermo shall immediately cleanup any spill which occurs during the loading, unloading or transfer of used oil at the facility.

- I.2. The operator shall call 911 when warranted to summon emergency personnel to the scene.
- I.3. The operator shall take action to prevent the spilled material from spreading by utilizing absorbent, dirt, booms, pads, rags, etc. The operator should prevent used oil from entering any adjacent storm water drain, sewer drain system or leaving the facility boundary.
- I.4. In the event that more resources are required, the operator will contact a supervisor to dispatch a spill response team to help facilitate the mitigation and/or remediation of the spill.
- I.5. Used oil spills exceeding 25 gallons, or smaller quantities that pose a risk to human health and the environment, shall be reported to Thermo’s Environmental Compliance Manager and to the Utah Department of Environmental Quality immediately after containment of the spill (Table I.5). The report must follow the reporting requirements of R315-15 and Thermo’s Used Oil Processor Permit. Within 15 days after any release of used oil that is reported under R315-15-9 of the Utah Administrative Code, the Environmental Manager shall submit to the Director a written report in accordance with the reporting requirements of R315-15-9 of the Utah Administrative Code.

Table: I.5: List of Agencies to Notify in Case of a Spill

Agencies Notification	Contact Phone Number
National Response Center	(800) 424-8802
Utah Department of Environmental Quality (within 24 hrs.)	(801) 536-4123

- I.6. Thermo’s employees shall report any spills to facility management, regardless of the volume. Employees are exempted from reporting de minimis drips to management that are immediately cleaned up by the responsible employee (Table I.6):

Table: I.6: Emergency Contacts List (Company Personnel)

Contact Person	Title	Contact Information
Merv Leituala	Oil Terminal Manager	Mobile: 385-249-8491 Office: 801-596-4803 Email:leituala.mervyn@cleanharbors.com
Joe Valerio	Area Terminal Director	Mobile: 509-998-6671 Email: jvalerio@emeraldrenews.com
Salt Lake City Fire Response (In case of fire or injury)	NA	911
Clean Harbors	Response/Cleanu p Contractor	Office: 800-645-8265

- I.7. Thermo’s operators shall submit a completed spill report to a supervisor at or before the end of the operators shift (Attachment 3-Appendix 1- Spill Report Form).







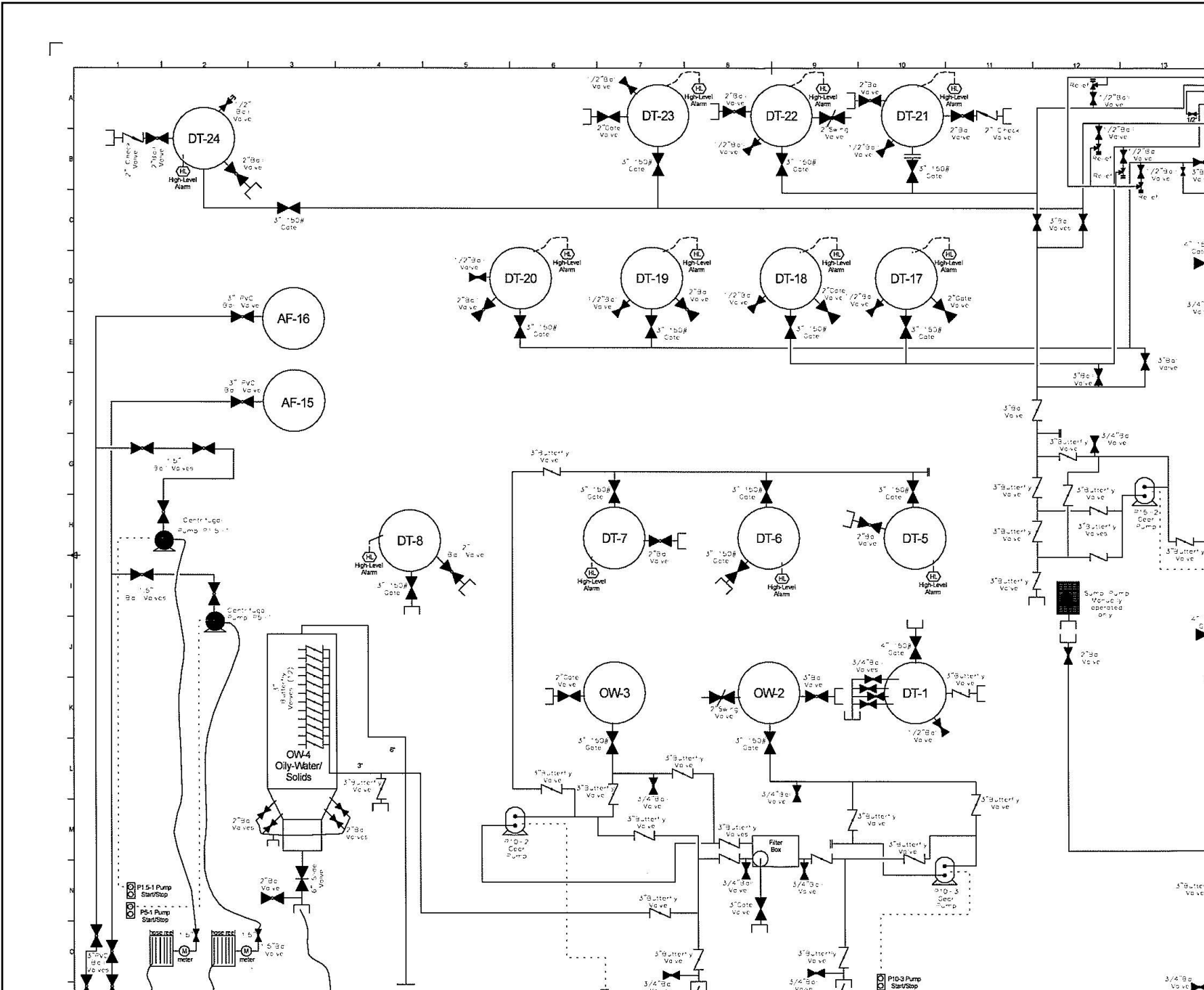

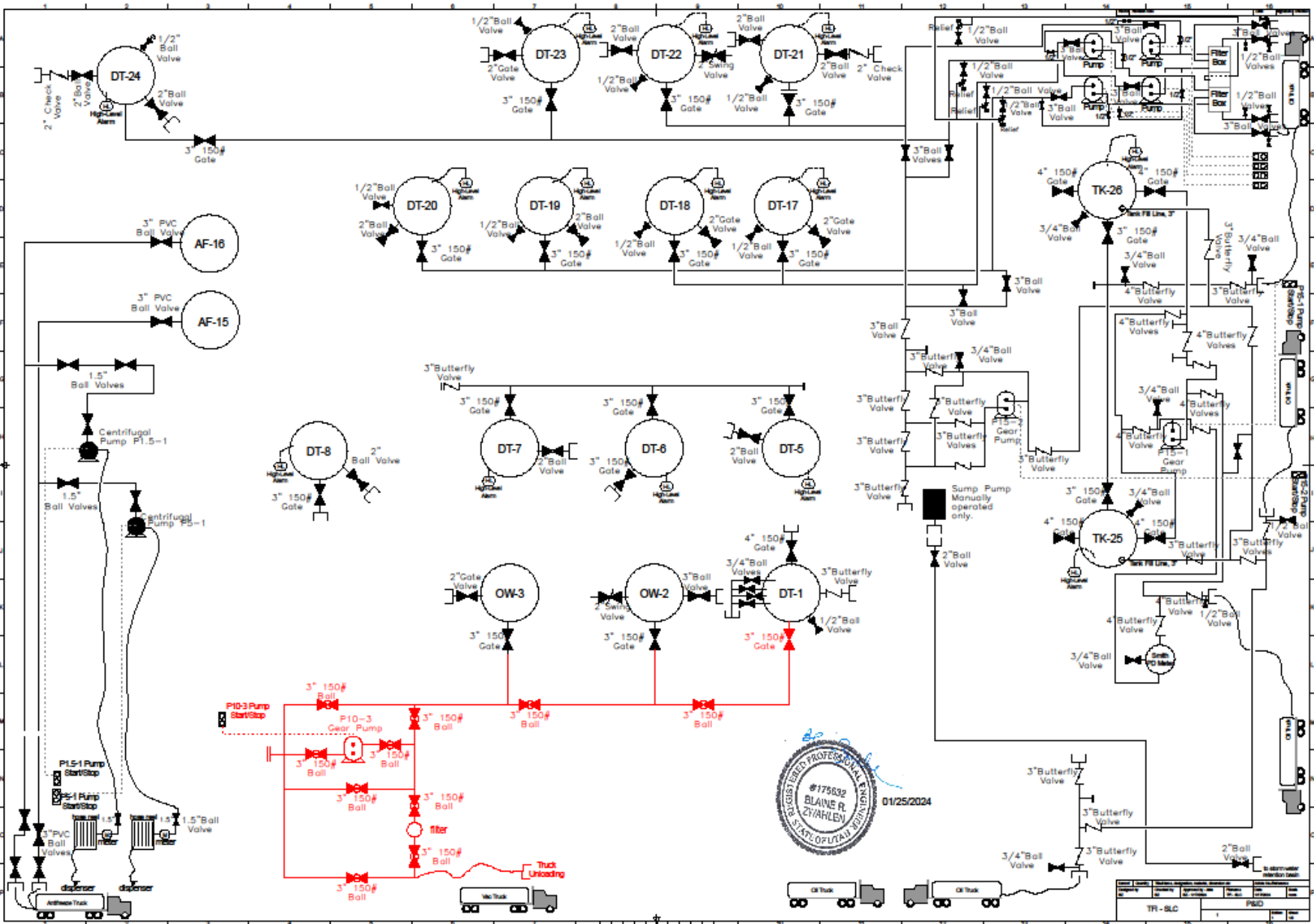









Attachment 3 - Appendix 1: Spill Report Form

Part A: Discharge Information		Name of Employee Reporting Spill:	
<p style="text-align: center;">General information when reporting spill to outside agencies</p> <p>Name: Thermo Fluids, Inc.</p> <p>Address: 3545 West 500 South Salt Lake City, UT 84104</p> <p>Telephone: 801-433-1114</p> <p>Owner/Operator: Thermo Fluids, Inc.4301 West Jefferson Street Phoenix, AZ 85043</p> <p>Primary Contact: Merv Leituala, Oil Terminal Manager Work: 801-596-4803 Cell (24 hrs): 385-249-8491</p>		<p>Type of oil:</p>	<p>Discovery date and time:</p>
		<p>Total quantity released:</p>	<p>Discharge date and time:</p>
		<p>Location/Source:</p>	<p>Affected media:</p> <p><input type="checkbox"/> Soil</p> <p><input type="checkbox"/> Surface Waters</p> <p><input type="checkbox"/> Storm Drain</p> <p><input type="checkbox"/> Sewer/POTW</p> <p><input type="checkbox"/> Other</p>
<p>Nature of discharges, environmental/health effects, and damages:</p>			
<p>Actions taken to stop, remove, and mitigate impacts of the discharge:</p>			
Part B: Notification Log			
Discharges of any Amount	Date and Time	Name of Person Receiving the Call	
<p>Merv Leituala Oil Terminal Manager Work: 801-596-4803 Cell (24 hrs): 385-249-8491</p>			
Discharges Exceeding 25 gallons	Date and Time	Name of Person Receiving the Call	
<p>Salt Lake City Fire Department/Other 911</p>			
<p>Utah Department of Environmental Quality (801) 536-4123</p>			
<p>Other Notification Information:</p>			

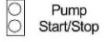
Attachment 4 Piping and Instrument Diagram





Description	Symbol	Description	Symbol
Gate Valve	 Gate	Transport Truck	
Ball Valve	 Ball	Hose Connection	
Butterfly Valve	 Butterfly	Transfer Hose	
Slide Valve	 Slide Valve	Storage Tanks	
Swing Valve	 Swing Valve	Smith Positive Displacement (PD) Flow Meter	
Check Valve	 Check	Filter Box	
Gear Pump	 Pump, Gear	Start/Stop Switch for Pump	
Sump Pump	 Sump Pump	Thermal Relief Valve	
Centrifugal Pump	 Pump, Centrifugal	Flow Meter	
High Level Alarm and Electronic Tank Gauge	 High-Level Alarm	Dispenser	

DT-1	27,073	Used Oil / Oily Water
OW-2	14,763	Oily Water
OW-3	20,344	Oily Water
OW-4	20,000	Oily Water/Solids
DT-5	12,263	Univ. Waste A/F
DT-6	12,263	Univ. Waste A/F
DT-7	12,263	Univ. Waste A/F
DT-8	16,144	Univ. Waste A/F
OW-9		Oil/Water Separation
AF-15	9,487	Antifreeze
AF-16	6,110	Antifreeze
DT-17	19,905	Used Oil
DT-18	19,905	Used Oil
DT-19	19,905	Used Oil
DT-20	19,905	Used Oil
DT-21	19,905	Used Oil
DT-22	19,905	Used Oil
DT-23	21,020	Used Oil
DT-24	20,558	Used Oil
TK-25	259,095	Used Oil / Oily Water
TK-26	259,095	Used Oil



Serial	Quantity	Inventory	Integration	Material	Material	Unit	Material
Number		Location	Code	Code	Code	Code	Code
TFI - SLC							

Attachment 5

Sample Collection Procedures

A. General

- A.1. Bulk shipments of used oil shipped directly from the facility to facilities that burn the used oil as fuel shall meet the specification requirements of R315-15.1.2 of the Utah Administrative Code prior to shipment.

B. Tank Lock-Down Procedure

- B.1. Used oil tanks will be tested individually. The operator shall “lock down” the tank valve so that used oil cannot be added or removed from the tank. The operator shall record the time and date that the tank was locked down and other information required by this Permit on the tank record. Used oil samples must be analyzed by a Utah certified laboratory for the methods utilized.
- B.2. Facility management shall review and verify the analytical results have met or failed to meet the specification requirements of R315-15-1.3 UAC prior to shipment of used oil to another facility.
- B.2.a. Used oil determined to be “on” or “off” specification may be: 1) further processed by the Permittee (e.g. blended in facility tanks); 2) shipped to an “on” or “off” specification burner, as applicable; or 3) shipped (correctly manifested) to another used oil processor for additional processing.
- B.3. The operator shall record the time and date that the lock was removed from the tank in the operating record. Compliance with Condition B.3 may be satisfied by the information recorded on the tank log as required by Condition I.F.3.b.

C. Tank Sampling Procedure (Recirculation Method)

C.1. Step 1

Lock down the tank valve. Circulate the tank for approximately 5-10 minutes. Unlock the sample port and remove the cap, open the sample port valve and clear the line. After the line has been purged of uncirculated oil, open the sample port valve and pull a sample from the tank sample port using a 32 oz. sample jar. The sample port is located approximately 6 ft. off the bottom of the tank. Fill the sample jar ½ way. Wipe off sample port with an absorbent pad, place the cap back on the sample port and lock the cap.

C.2. Step 2

Take large sample jar and split into two smaller 8 oz. sample jars. One sample jar is labeled with: date, company name and tank number. This sample is sent to a Utah certified laboratory for an on specification fuel analysis. The other sample jar is the retain sample as is labeled with the date, tank number, time sample was pulled, name of the individual who pulled the sample and the word “retain”.

C.3. Step 3:

Completely drain residual used oil from the large sample jar and wipe clean with an absorbent pad

- C.4. **Step 4**
Label sample jar and fill out chain of custody for lab. Follow lab procedures for proper packing and shipping.
- D. Drums/Containers ≤ 275 gallons Sampling Procedure**
- D.1. Sampling Method ASTM- ASTM-D7831 – COLIWASA Sampling Device
COLIWASA Sampling Device: Glass or Polypropylene/ plastic type tube or “tank” sampler with a stopper at one end attached by a rod running the length of the tube to a locking mechanism at the other end.
- D.2. **Step 1**
Open the COLIWASA by placing the stopper mechanism or inter tube in the open position.
- D.3. **Step 2**
Lower the tapered end of the outer sampling tube in the liquid at a rate that allows the liquid level inside and outside to the tube to equalize. If the level of the liquid in the sample tube is lower than that outside the sampler, the sampling rate is too fast and a non-representative will result.
- D.4. **Step 3**
Use the stopper or tube mechanism to close the COLIWASA when it has reached the desired depth.
- D.5. **Step 4**
Slowly withdraw the sample from the liquid, keeping the seal closed and holding the tube in a vertical position. Wipe the exterior of the sampler tube with a rag or allow the excess liquid to drain back into the container.
- D.6. **Step 5**
Open sample jar and dispense the entire contents from COLIWASA into sample jar.
- D.7. **Step 6**
Label sample jar and fill out chain of custody for laboratory or screen sample the sample with a CLOR-D-TECT® halogen test kit (EPA Method 9077) and document the results. Follow any required laboratory procedures for proper packing and shipping.

Attachment 6 Analysis Plan

A. Halogen Field Screening Methods

A.1. The Permittee shall screen, when applicable, used oil or oily water subject to R315-15 of the Utah Administrative Code in accordance with the following requirements:

A.1.a. CLOR-D-TECT® halogen test kit (EPA Method 9077) for oil containing less than 20% water; or

A.1.b. HYDROCLOR-Q® test kit if the oil contains between 20% and 70% water using the following conversion formula:

$$\text{True Halogen Concentration} = \text{Reading Syringe} + [(10 + \text{ml oil in sample})/10]$$

Example: sample contains 6 ml water and 4 ml oil (60% water) and the syringe reading is 2,000 ppm, then the true concentration is:

$$2,000 \text{ ppm} [(10 \text{ ml} + 4 \text{ ml})/10] = 2,800 \text{ ppm}$$

A.1.c. HYDROCLOR-Q test kit without correction for oil containing greater than 70% water.

A.2. Field screening kits (CLOR-D-TECT® and HYDROCLOR-Q®) shall be unexpired to be considered valid for determining the halogen content.

B. Quality Control Sample

B.1. Prior to off-loading used oil/oily water from tankers into the facility storage tanks, a quality control sample (duplicate) shall be collected from the tanker and screened for halogens using either a CLOR-DTECT or HYDROCLOR-Q test kit, as applicable.

B.2. Operators shall document in the facility's operating record, that the quality control sample was collected and screened for each load received at the facility.

C. Laboratory Analytical Methods for Used Oil Analysis

C.1. Used oil samples collected and analyzed by the Permittee to evaluate if the used oil no longer requires additional processing, prior to shipment from the facility shall be analyzed by a Utah-certified laboratory using the preparatory and analytical methods listed in Attachment 6, Table C.

D. Rebuttable Presumption

D.1. The Permittee may rebut the hazardous waste presumption in accordance with R315-15-4.5 of the Utah Administrative Code if the Permittee can demonstrate that the used oil does not contain significant concentrations of any of the halogenated hazardous constituents listed in Appendix VIII of EPA CFR 40, Part 261 which includes volatiles, semi-volatiles, PCBs, pesticides, herbicides and dioxin/furans. Generator knowledge may be used to exclude testing for pesticides, herbicides and dioxins/furans unless coming from a process where this is expected.

Table C: Specification Testing: Sample Preparation and Analytical Methods

Constituents	Regulatory Levels	Sample Preparatory Methods	Analytical Methods (SW-846, EPA)
Arsenic	≤ 5 mg/kg	3031 or 3051A	6010C/6010D
Cadmium	≤ 2 mg/kg	3031 or 3051A	6010C/6010D
Chromium	≤ 10 mg/kg	3031 or 3051A	6010C/6010D
Lead	≤ 100 mg/kg	3031 or 3051A	6010C/6010D
Flash Point	≥ 100 degrees F	1010A or 1020B	1010A or 1020B
Total Halogens	≤ 1000 mg/kg	9075 or 9076	9075 or 9076
PCBs	< 2 mg/kg	3580A/3665A (Cleanup)	8082A

E. PCB Contaminated Used Oil

E.1. Laboratory testing for PCBs shall be conducted in accordance with R315-15-18(d) of the Utah Administrative Code when used to satisfy any requirements of R315-15 of the Utah Administrative Code and this Permit.

E.2. The required PCB sample preparation and analytical methods are listed in Table E.1.

Table E.1: PCB Sample Preparation and Analytical Methods

Sample Preparation Methods	Analytical Method	Analytes *	
		PCB CAS RN	PCB Aroclor®
3500C (General) 3580A (Preparation) 3665A (Cleanup)	8082A	12674-11-2	1016*
		147601-87-4	1210
		151820-27-8	1216
		11104-28-2	1221*
		37234-40-5	1231
		11141-16-5	1232*
		71328-89-7	1240
		53469-21-9	1242*
		12672-29-6	1248*
		165245-51-2	1250
		89577-78-6	1252
		11097-69-1	1254*
		11096-82-5	1260*
		37324-23-5	1262
11100-14-4	1268		

* Note: Analyses of the Aroclors® bolded/* in the last column are mandatory to analyze.

Attachment 7

Used Oil Loading and Unloading Operations

A. Training

- A.1. Thermo Fluids, Inc. personnel or other representatives who load and unload used oil at the facility will be trained in these procedures prior to conducting these operations.

B. Truck/vehicle Used Oil Collection Loading and Unloading Procedures

- B.1. Driver and any assistant(s) will wear safety glasses, gloves and other appropriate PPE.
- B.2. Vehicles will be positioned with safety brake applied and wheels chocked.
- B.3. Driver will take beginning measurement of used oil in vehicle or container/storage tank to determine how much volume is available in order to avoid overflowing of the vehicle or container/storage tank.
- B.4. Complete the duplicate sample quality control requirement of Condition B of Attachment 6 by screening the used oil with a CLOR-D-TECT® or HYDROCLOR-Q test rebuttable presumption requirements following the testing procedures listed in the "Used Oil Analysis/Rebuttable Presumption Plan" portion of this permit.
- B.5. Hose screens and gaskets will be checked each time prior to connecting to verify they are sound and not plugged. After checking, securely tighten hose fittings to minimize potential of spill. Place a drip bucket below connections to catch drips.
- B.6. Place the end of hose in appropriate vehicle or container/storage tank manifold connection to be pumped or filled. Operator must remain at the scene, and he/she must remain in charge and maintain control of the operation throughout the entire used oil transfer operation.
- B.7. After the vehicle or container/tank is emptied/filled; re-check hose screens prior to pumping/filling the next container. After all used oil is pumped, clean hose screen, disconnect hose from truck and store appropriately. Collect and empty the spill bucket into used oil into tank, and clean up any remaining drips, leaks, or spills. Before leaving, confirm all tanks and container covers are closed and locked.

Attachment 8
Facility Closure Plan

A. General

- A.1. Thermo Fluids Inc. shall at time of closure comply with all of the clean-up and requirements of R315-15-5 and this Closure Plan (Attachment 8) and Appendix 1- Estimated Closure Costs Tasks.

B. Soil and Groundwater Testing (Task 1)

- B.1. At time of the closure of the facility, the Permittee shall sample the soil and groundwater (RCRA 8 metals, Volatiles, Semi-Volatiles, PCBs) to determine potential contamination from operational activities. The Permittee shall submit a Level IV data validation analytical package from a Utah certified laboratory, within 30 days of receipt, to the Director for review and approval.

C. Plant Decommission Certification (Task 2)

- C.1. Plant decommission, at time of closure, requires removal of all used oil. Other media shall be recovered from all containers and any other ancillary equipment.
- C.2. The Permittee shall dispose of used oil at an appropriately permitted management facility.
- C.3. Hazardous waste, non-hazardous waste, rinsate water, and scrap metal generated shall be transported to a recycling facility or a waste disposal facility as applicable.

D. Closure Certification Costs (Task 3)

- D.1. Closure of the facility in accordance with requirements of this Permit shall be verified by a Utah certified independent Professional Engineer (P.E.), and submitted to the Director for final approval.

Attachment 8 – Appendix 1

Estimated Closure Costs

Task	Task Description	Quantity	Units	Rate	Total Cost
1	Soil and Groundwater Testing				
	Sampling (labor)	10	Hours	\$75.00	\$750.00
	Sampling (labor) Supervisor	10	Hours	\$80.00	\$800.00
	Soil/Groundwater Samples/ Analytical Testing	24	Each	\$550.00	\$13,200.00
	Drilling for soil sample collection	10	Hours	\$175.00	\$1,750.00
	Equipment Rental	1	Days	\$500.00	\$500.00
	Site Sampling and Analytical Sub-Total				\$17,000.00
2	Facility Decommission				
	Prepare Health & Safety Plan	1	Plan	\$1,500.00	\$1,500.00
	Removal, Transportation, Sale and/or Recycling of Used Oil	777,822	Gallons	\$0.08	\$62,226.00
	Tanks Rinsate Heel (Sludge)	4,750	Gallons	\$1.89	\$8,978.00
	Tanks Rinsate Oily Water	8,750	Gallons	\$0.79	\$6,913.00
	Diesel Fuel for Rinsate	1,000	Gallons	\$2.79	\$2,790.00
	Rinsate Analytical	15	Each	\$525.00	\$7,875.00
	Tanks(s) Cleaning/Decontamination	18	Tank	\$1,817.00	\$32,706.00
	Tank Cleaning Mobilization / Port to Port	15	Days	\$34.00	\$510.00
	Tanks Decontamination Supplies, Meters, PPE (per day)	11	Days	\$275.00	\$3,025.00
	Tank Decontamination Facility Fees; Energy Fees	1	Each	\$4,830.00	\$4,830.00
	Used Oil Drums Treatment/Disposal	50	55 DM	\$60.00	\$3,000.00
	Transportation Containerized Used Oil	1	Each	\$3,052.00	\$3,052.00
	Fuel Surcharge (Containerized Transportation)	1	Each	\$244.00	\$244.00
	Oil Filter Disposal	40	Tons	\$43.00	\$1,720.00
	Oil Filter Containerized Waste Transportation	4	Each	\$425.00	\$1,700.00
	Waste Characterization Containerized Material	7	Each	\$863.00	\$6,041.00
	Soil Removal (labor)	10	Hours	\$75.00	\$750.00
	Soil Removal Supervisor	10	Hours	\$80.00	\$800.00
	Disposal PCB contaminated soil (<50 ppm)	20,000	lbs.	\$0.65	\$13,000.00
	Transportation PCB contaminated soil (<50 ppm) to disposal facility	1	Each	\$7,100.00	\$7,100.00
	Universal Waste Antifreeze Transportation to Recycler (5,000 gal loads)	10	Loads	\$2,433.00	\$24,330.00
	Retention Pond Plastic Liner - Cut Up 30 yd. Bin	1	Tons	\$43.00	\$43.00
Retention Pond Plastic Liner Transportation	1	Each	\$425.00	\$425.00	
Retention Pond Water Disposal	100,000	Gallons	\$0.24	\$24,000.00	
Retention Pond Water transportation	20	Each	\$460.00	\$9,200.00	
Plant Decommission Sub-Total				\$226,758.00	
3	Closure Certification				
	Independent P.E. Verification	1	Each	\$3,500.00	\$3,500.00
	Division of Solid & Hazardous Waste Review	50	Hours	\$100.00	\$5,000.00
Final Closure Verification Sub-Total				\$8,500.00	
Total Closure Costs				\$252,258.00	